

RAGNOR 20L

HYDRAULIC CONTAINER TILTER LOADER



Ragnor Hydraulics

AN ISO 9001:2015 COMPANY

REG. & OFFICE ADDRESS: #232, SECTOR-6, IMT MANESAR, GURGAON

PHONE: 9871695569,9802222494

MAIL: sales@ragnorhydraulics.com, info@ragnorhydraulics.com

WEB: www.ragnorhydraulics.com

SPECIFICATIONS

- *SOLID STRUCTURE DESIGNED TO RESIST STRESSES AND SHOCKS*
- *LOADING SUITABLE FOR SEMITRAILER*
- *AUTOMATIC DOORS OPENING*
 - *CLOSING (NO RISKS FOR OPERATOR)*
- *ONLY 1 OPERATOR NEEDED*
- *+20% VOLUME OF BULK GOODS LOADED IN THE CONTAINER*
- *-20% TRANSPORT COSTS*
- *INSTALLATION IN 24 HOURS*
- *C.E. / U.L. CERTIFICATION*

SEMI-AUTOMATIC HYDRAULIC BLOCKING SYSTEM ON 4 CONTAINER'S CORNERS

LOADING & UNLOADING BY FORK LIFT.

Ragnor 20L Technical Specifications:

Load Capacity 30 Ton

Container 20'

Container Locking *Semi-automatic hydraulic blocking system on 4 container's corners*

Width 4940 mm

Length 7500 mm

Height 1480 mm

Tilting *Standard: 0° - 70°
Optional: 0°- 90°*

IDEAL FOR BULK PRODUCTS, LIKE

- CEREALS
- FERTILIZERS
- FLOURS
- COFFEE
- CONCRETE
- RAGS
- PELLETS
- METAL SCRAP
- MINERALS
- GRAINS

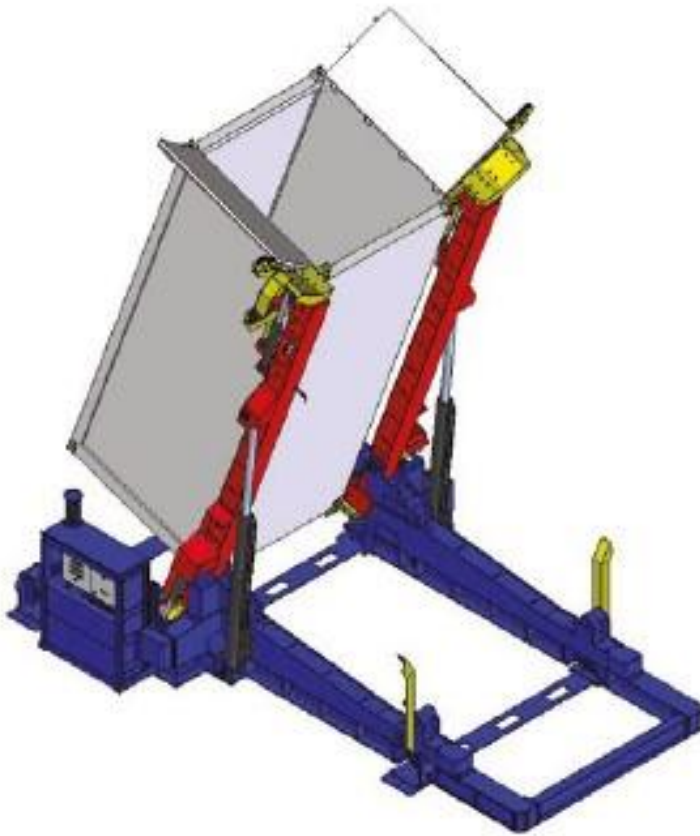

Options:

- Hydraulic tilting adjustable from 0° to 90°, max 30 Tons
- Loading suitable for:
 - forklift
 - reach stacker
- Certified weighing system, connected with factory's ERP
- Remote control with digital display for weight and inclination read out
- Ground guides for an easier access of the semitrailer
- Movable machinery within the production area.

RAGNOR 40L

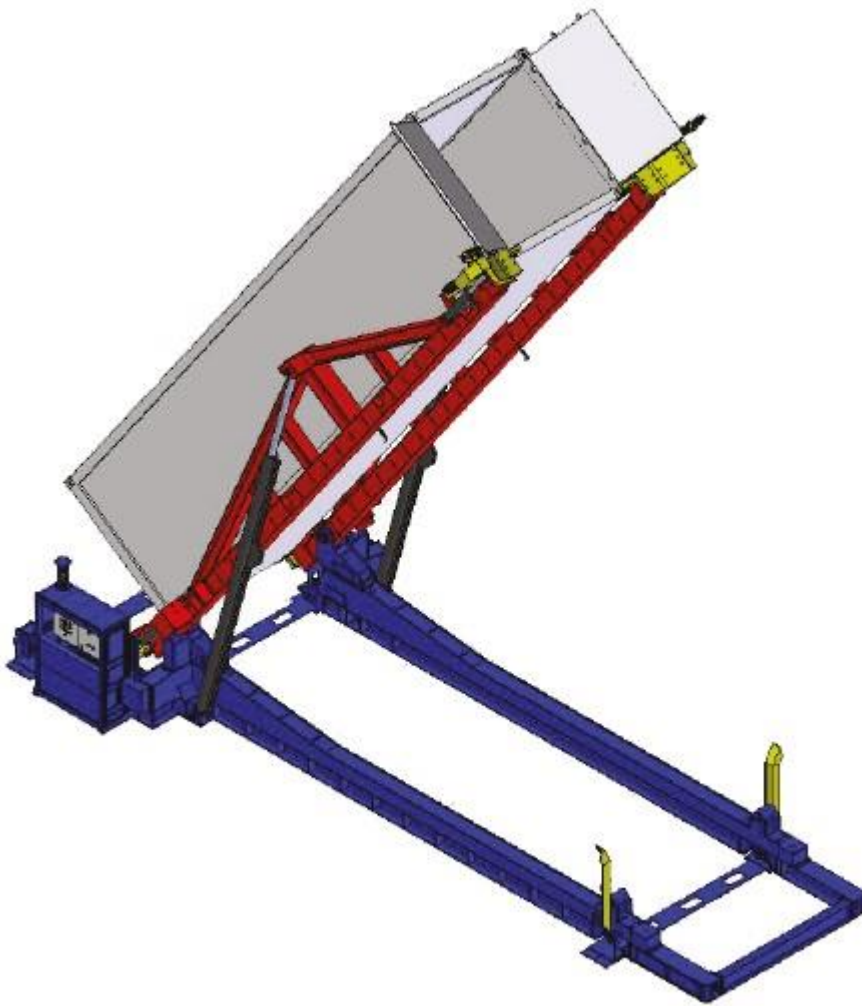

SPECIFICATIONS

- **SOLID STRUCTURE DESIGNED TO RESIST STRESSES AND SHOCKS**
- **LOADING SUITABLE FOR SEMITRAILER**
- **AUTOMATIC DOORS OPENING**
– **CLOSING (NO RISKS FOR OPERATOR)**
- **ONLY 1 OPERATOR NEEDED**
- **+20% VOLUME OF BULK GOODS LOADED IN THE CONTAINER**
- **-20% TRANSPORT COSTS**
- **INSTALLATION IN 24 HOURS**
- **C.E. / U.L. CERTIFICATION**

SEMI-AUTOMATIC HYDRAULIC BLOCKING SYSTEM ON 4 CONTAINER'S CORNERS

LOADING & UNLOADING BY FORK LIFT.

Ragnor 40 L Technical Specifications:

Load Capacity 30 Ton

Container 40'

Container Locking Semi-automatic hydraulic blocking system on 4 container's corners

Width 5840 mm

Length 12000 mm

Height 1900 mm

Tilting Standard: 0° - 70°

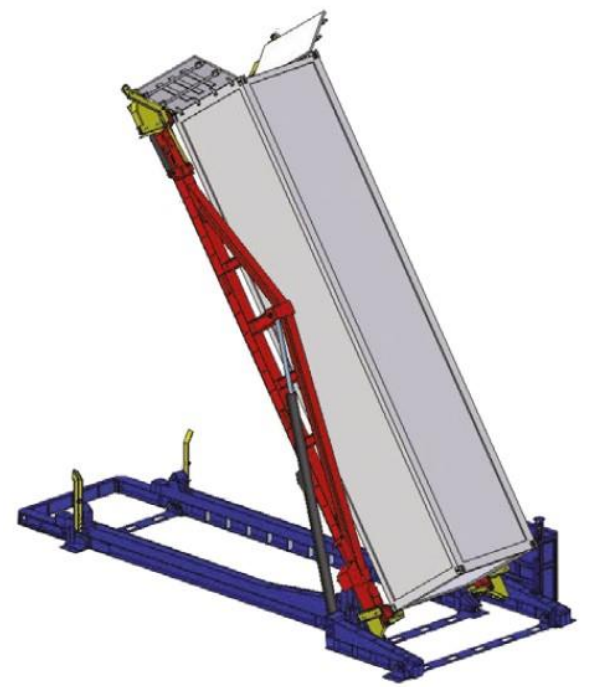
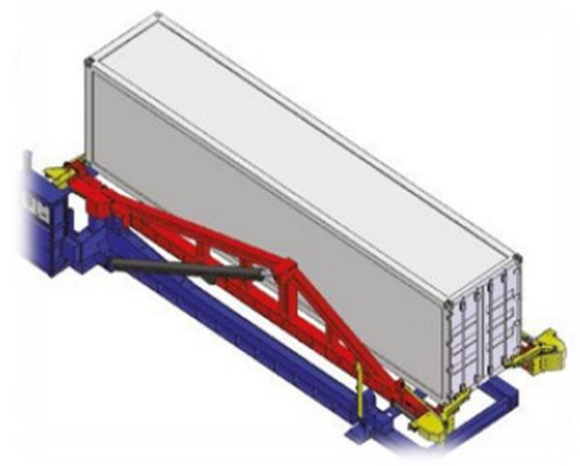
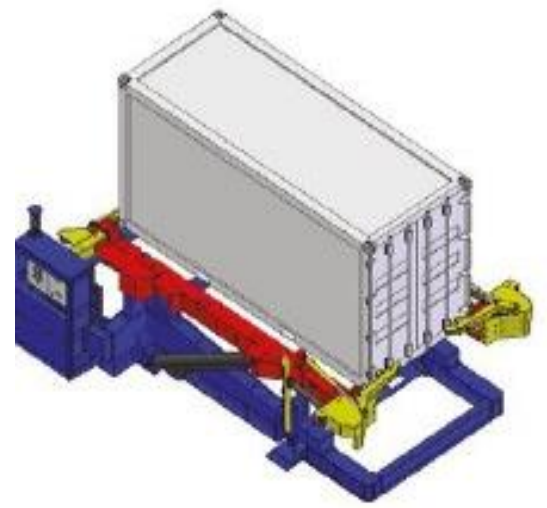

Our Quality :

- All structures designed and checked with FEM structural and vibrational analysis
- High production output
- Easy maintenance
- High operational flexibility
- Low energy consumption
- Service intervention within 24-36 hrs
- Taylor made design

RAGNOR 20U

HYDRAULIC CONTAINER TILTER UNLOADER



SPECIFICATIONS

- *SOLID STRUCTURE DESIGNED TO RESIST STRESSES AND SHOCKS*
- *LOADING SUITABLE FOR SEMITRAILER*
- *ONLY 1 OPERATOR NEEDED*
- *-50% UNLOADING TIME FOR BULK GOODS*
- *INSTALLATION IN 24 HOURS*
- *C.E. / U.L. CERTIFICATION*
- *SEMI-AUTOMATIC HYDRAULIC BLOCKING SYSTEM ON 4 CONTAINER'S CORNERS*

Ragnor 20U Technical Specifications:

Load Capacity 30 Ton

Container 20'

Container Locking Semi-automatic hydraulic blocking system on 4 container's corners

Width 4940 mm

Length 7500 mm

Height 1480 mm

Tilting Standard: 0° - 50°
Optional: 0°- 90°

IDEAL FOR BULK PRODUCTS, LIKE

- CEREALS
- FERTILIZERS
- FLOURS
- COFFEE
- CONCRETE
- RAGS
- PELLETS
- METAL SCRAP
- MINERALS
- GRAINS

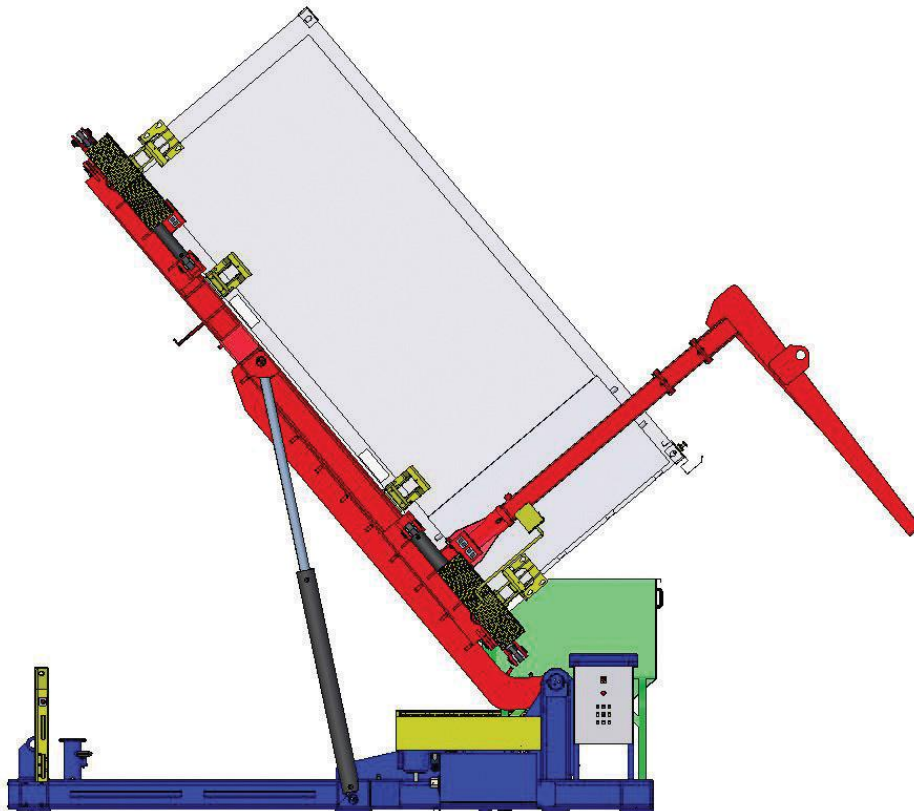

Options:

- Hydraulic tilting adjustable from 0° to 50°, max 30 Tons
- Loading suitable for:
 - forklift
 - reach stacker
- Remote control with digital display for inclination read out
- Top shield protection for unloading area
- Ground guides for an easier access of the semitrailer
- Movable machinery within the production area

RAGNOR 40U



SPECIFICATIONS

- *SOLID STRUCTURE DESIGNED TO RESIST STRESSES AND SHOCKS*
- *LOADING SUITABLE FOR SEMITRAILER*
- *ONLY 1 OPERATOR NEEDED*
- *-50% UNLOADING TIME FOR BULK GOODS*
- *INSTALLATION IN 24 HOURS*
- *C.E. / U.L. CERTIFICATION*
- *SEMI-AUTOMATIC HYDRAULIC BLOCKING SYSTEM ON 4 CONTAINER'S CORNERS*

IDEAL FOR BULK PRODUCTS, LIKE

- *CEREALS*
- *FERTILIZERS*
- *FLOURS*
- *COFFEE*
- *CONCRETE*
- *RAGS*
- *PELLETS*
- *METAL SCRAP*
- *MINERALS*
- *GRAINS*

Ragnor 40U Technical Specifications:

Load Capacity 30 Ton

Container 40'

Container Locking Semi-automatic hydraulic blocking system on 4 container's corners

Width 4940 mm

Length 14850 mm

Height 1480 mm

Tilting Standard: 0° - 50°
Optional: 0°- 90°

Our Quality

- All structures designed and checked with FEM structural and vibrational analysis
- High production output
- Easy maintenance
- High operational flexibility
- Low energy consumption
- Service intervention within 24-36 hrs
- Taylor made design

